



RHM 06

Coriolis Mass Flow Meter for Batching/Filling and Accurate Measurement

General Flow Control / Additive Dosing / Mixing and Batching /
Chemical Injection / Package and Container Filling





Features

- Typical measuring range up to 36 kg/min (79.37 lb/min)
- Pressure ratings up to 1722 bar (24975.5 psi)
- Temperature ratings from -196 to +350 °C (-320 to +662 °F) – extended on request
- Mass flow uncertainty down to 0.05 %
- Repeatability down to 0.05 %
- 4 kHz measurement updates and response time of less than 10 ms when used with RHE 40 Series transmitters
- Accurately measure flow rates down to 100 g/min
- The Rheonik **AnyPipeFit Commitment** provides custom process connection type and size flexibility on any meter to suit your existing plant, saving time and expense on installation costs
- Compact design with minimal pipeline footprint
- Approved for use in hazardous areas
- SS 304 Stainless steel enclosure, SS 316L optional
- Integral and remote transmitter versions available

General Specification Overview

| | |
|--|--|
| Nominal Flow (Q_{nom})* | 25 kg/min (55.1 lb/min) |
| Maximum Flow (Q_{max})* | 36 kg/min (79.4 lb/min) |
| Typical Minimum Flow (Q_{min})* | 0.1 kg/min (0.22 lb/min) |
| Serial Tube / Single Path | Flow rates Q_{max} , Q_{nom} and Q_{min} for "serial" sensors will be 50% of the above listed parallel/dual path version. |
| Operating Temperature | Fluid temperature range options cover from -196 °C to +350 °C (-320 °F to +662 °F) For integral transmitter versions please refer to transmitter datasheet |
| Ambient Temperature | -50 °C to +80 °C (-60 °F to +180 °F) (standard), versions available for installation in vacuum chamber (-260 °C / -430 °F) or oven (up to +210 °C / +410 °F) (optional) |
| Pressure Ratings | Up to 1722 bar / 24975 psi – dependent upon material |
| Electrical Connection Sensor w/o Integral Transmitter | M20 x 1.5 standard cable entry for JM, SM terminal box versions Optional entries available : ½" NPT or M25 x 1.5 (only for SM) or ¾" NPT (only for SM) M16 x 1.5 standard cable entry for PM terminal box version Max. cable length to remote RHE transmitter 100 m/330 ft |
| Sensor Enclosure Materials | Stainless steel 304 (standard), SS 316L (optional) Coated aluminum terminal box, SS 316L terminal box (optional) |
| Enclosure Type | Protection class IP66 (IP66 is mostly equivalent to NEMA4X) Optionally IP66-IP67 (IP67 declared by manufacturer, IP67 is mostly equivalent to NEMA 6) |
| Wetted Materials | Flow tubes SS 316L, SuperDuplex or Alloy C22 Manifolds SS 316L, seals FKM, FFKM, FVMQ, EPDM Standard flanges SS 316Ti, other connections SS 316L Additional/customer specific materials available upon request |
| Process Connections | Nearly any - The Rheonik AnyPipeFit Commitment covers a wide range of process connections types and sizes. Consult factory for types/sizes not listed in this data sheet on the Mechanical Construction pages |
| Pressure Rating Compliance | PED 2014/68/EU Article 4, Section 3 (SEP) |
| Certifications and Approvals | ATEX / IECEx Approvals Zone 0, 1, 2 (details see page 19) North American Approvals Cl. I, Div. 1, 2, Gr. A, B, C, D, Zone 0, 1, 2 OIML, MID custody transfer approval American Bureau of Shipping (ABS) DNV approval for marine applications |
| Testing and Inspection | All sensors are hydro tested, calibrated and supplied with a traceable calibration certificate. Customized calibration and testing services are available |
| Project Documentation and QA, Services | Rheonik offers a full set of services for large and complex engineering projects. Typical services offered are, but not limited to: <ul style="list-style-type: none"> • Certificates of origin and conformity, mill certificates • Data books including WPS-WPQR, WPQ, NDT, test & quality plans, functional testing, calibration procedures, customized packing, factory acceptance etc. • Painting to project specification • Start up and commissioning services on/offshore |
| Options | Customization services for machine integration. Consult factory |

* At Q_{nom} pressure drop across a parallel tube sensor will be approximately 2 bar (29 psi) for H₂O. Sensors can be operated at higher flow rates up to Q_{max} but pressure drop will be higher. Typical Minimum Flow Q_{min} is the recommended lowest flow rate for an accurate measurement. Sensors will measure flow rates lower than Q_{min} but uncertainty will increase beyond 1% of rate.

The flow rate specifications above relate to standard pressure, parallel tube, manifold sensor versions. Models with higher pressure ratings have increased wall thickness and will have higher pressure drops.

Calibration Options

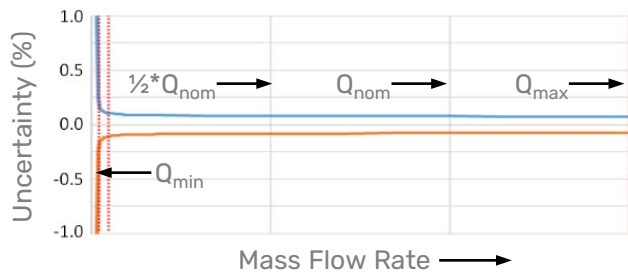

| Order Code | General Accuracy Calibration |
|------------|-------------------------------|
| A | Standard - 0.20 % Uncertainty |
| B | Premium - 0.15 % Uncertainty |

| Order Code | High Accuracy Calibration |
|------------|--|
| G | Premium Plus - 0.10 % Uncertainty |
| U | Ultimate - 0.05 % Uncertainty <i>Requires RHE 40 Series transmitter</i> |

| Order Code | Focused Calibration |
|------------|---|
| 1 | 0.10 % Low Flow Calibration* <i>Requires RHE 40 Series transmitter</i> |
| X | Customized Calibration** Consult factory |

* Low flow calibration focuses on the range from $\frac{1}{2} * Q_{nom}$ downwards to lower flow rates than on other calibrations. Often used for low pressure gas or very viscous liquids

** Customized calibration uses specific calibration points according to customer requirements

Reference conditions:
18-24°C Water @ 1-3 bar

| Order Code | Density Calibration / Performance (Liquid) |
|------------|--|
| N | No Density Calibration |
| S | Standard ± 0.001 kg/l Uncertainty |
| D | Enhanced ± 0.0005 kg/l Uncertainty Requires High Accuracy or Focused Calibration Option |

Uncertainties and flow measurement turn-down

The turn down capability from Q_{nom} of the flow sensor is driven mainly by its zero point stability. At the very low end of the measuring range the uncertainty (u) is dominated by zero point stability.

- Zero point stability of a standard sensor with General Accuracy Calibration is: ± 0.00086 kg/min (0.0019 lbs/min).
- Zero point stability of a Gold Line sensor with High Accuracy or Focused Calibration is ± 0.00058 kg/min (0.00128 lbs/min).
- For flow $Q \geq ZP \text{ stability} / (\text{Base Calibration uncertainty} / 100) \rightarrow u = \text{calibration uncertainty}$
- For flow $Q < ZP \text{ stability} / (\text{Base Calibration uncertainty} / 100) \rightarrow u = (\text{zero stability} / Q) * 100$

Uncertainties from environmental and process conditions

If sensors are not zeroed at operating conditions, minor additional uncertainties can arise from elevated temperatures and pressures:

- ± 0.001074 % of maximum flow per °C
- ± 0.000857 % of maximum flow per bar.

Process temperature effect on density:

- Additional uncertainty of ± 0.000064 g/cm³ per °C difference from calibration temperature with standard density calibration
- Additional uncertainty of ± 0.000054 g/cm³ per °C difference from calibration temperature with enhanced density calibration.
- This effect can be mitigated by a simple field density adjustment at operating conditions.

Process pressure effect on mass flow:

The effect of pressure on flow measurement is 0.0001 % of rate per bar. Compensation is possible by pressure sensor input (analog input or digital write) or manual value entry into the transmitter.

Process pressure effect on density:

- The effect of pressure on density measurement is 0.00007 g/cm³ per bar. Compensation is possible by pressure sensor input (analog input or digital write) or manual value entry into the transmitter.

Premium Plus, Ultimate, Low Flow and Enhanced Density Calibration are only available in SS316L material, P1 lower pressure and N1 temperature range.

Applying Premium Plus calibration to higher pressure, special materials and/or non-standard temperature models will show higher zero uncertainties (up to 3 times higher than standard sensor).

Flow Measurement Repeatability

Standard Sensors ± 0.1 % of rate
Gold Line Sensors ± 0.05 % of rate

Temperature Measurement

Better than ± 1 °C

Pressure Drop

Every Coriolis flow sensor generates pressure drop across its inlet and outlet when in use. The amount of pressure drop generated is mainly a function of the flow velocity within its tubes and the flowing viscosity of the stream.

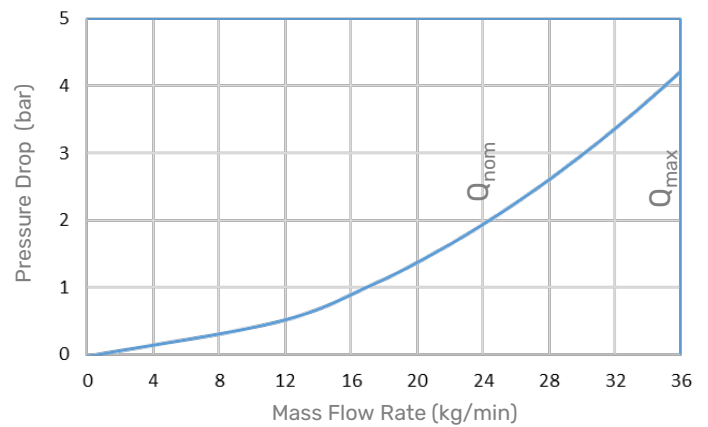

0 – 36 kg/min water, sensor with P1 pressure rating. Higher viscosities create higher pressure drop

Measurement Tube Materials and Pressure Ratings

The maximum pressure (p_{max}) of a sensor is determined by its lowest rated part. The lowest rated part can be either the measurement tube (p_{max} see table to the right), the connection block/manifold (p_{max} indicated in the Mechanical Construction section) or the process connection (for p_{max} see published standards or manufacturer information).

Note:

The material of the connection block/manifold is always SS 316L.

The material of the process connection of sealless sensor versions is usually the same as the measurement loops, however, could be different in special cases on PFT.

| Order Code | Material | 50°C / 122°F | 120°C / 248°F | 210°C / 410°F | 350°C / 662°F |
|------------|--------------------|--------------|---------------|---------------|---------------|
| P1 | SS 316L (standard) | 213 / 3089 | 189 / 2741 | 160 / 2321 | 136 / 1972 |
| P1 | Alloy C22 | 300 / 4351 | 267 / 3872 | 227 / 3292 | 189 / 2741 |
| P2 | SS 316L (standard) | 580 / 8412 | 516 / 7484 | 435 / 6309 | 370 / 5366 |
| P2 | SuperDuplex* | 580 / 8412 | 516 / 7484 | 435 / 6309 | N/A |
| P3 | SuperDuplex* | 910 / 13198 | 847 / 12285 | 760 / 11023 | N/A |
| P4 | SuperDuplex* | 1234 / 17898 | 1149 / 16665 | 1030 / 14939 | N/A |
| P5 | SuperDuplex* | 1722 / 24975 | 1603 / 23249 | 1438 / 20856 | N/A |

* Note minimum operating temperature for SuperDuplex stainless steel is -40 °C

Units: bar / psi

Other Materials

Other wetted materials may be possible for chemical compatibility, lower pressure drop, abrasion allowance, other application specific requirements. Rheonik can provide nearly any material for the wetted parts. Contact factory with specification for assessment and availability.

Mechanical Construction

Sensors are manufactured with two internal measurement tubes arranged side by side. In parallel or dual measurement path sensors (order code Pxx), these tubes are connected in parallel, and the flowing fluid is split equally between them. In serial or single measurement path sensors (order code Sxx), the internal tubes are connected end to end, creating a single path through which all fluid flows. Manifold designs have a removable inlet/outlet block/manifold and utilize seals between the manifold and sensor body. In sealless designs, the measurement tubes are continuous between the process connections and do not have seals. Manifold designs typically offer shorter delivery lead times and may have a lower pressure drop than sealless designs for the same flow rate.

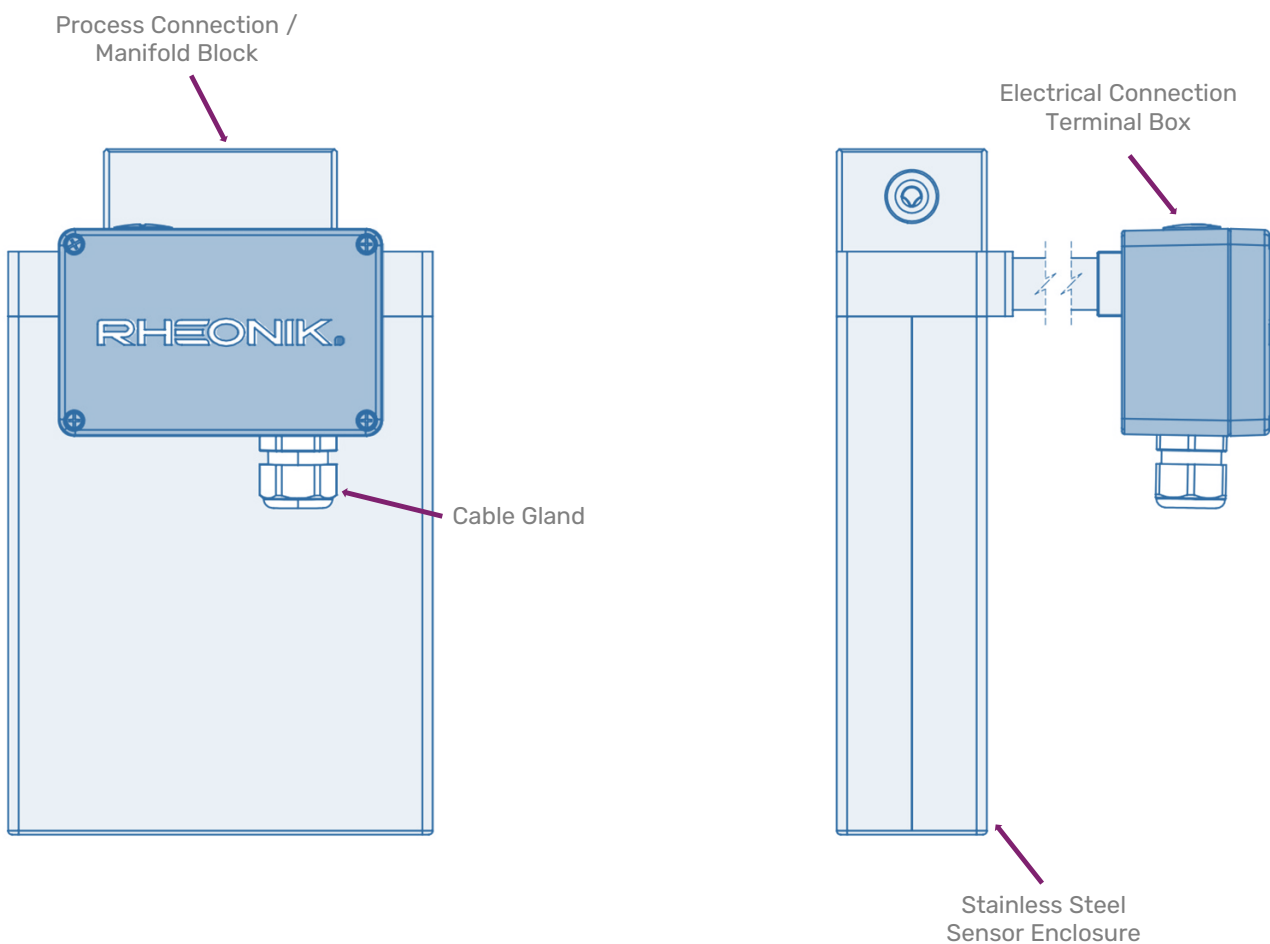

Note

All dimensions in the following pages are for standard design products. For customization of face-to-face length and/or process connection types other than the ones listed on the following page, please consult factory. Note that larger diameter flange process connections are always possible. The tolerance of the process connections is ± 2 mm.

Manifold design with threaded process connections

Parallel tube / dual measurement path

Order Codes: PM0/PH0

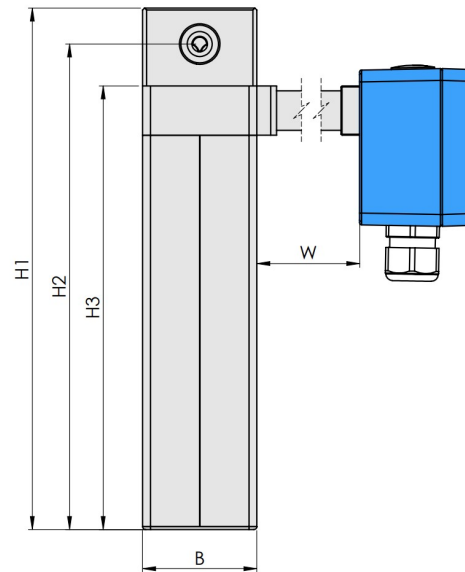
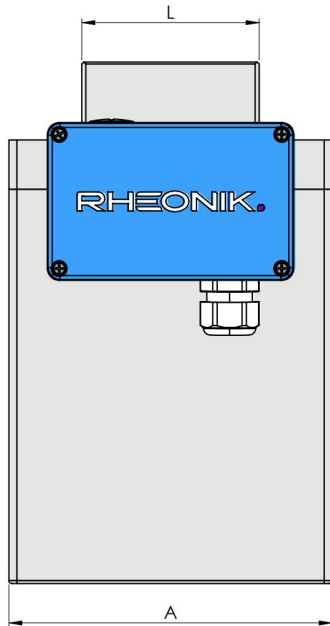

| PM0 / PH0 Process Connection | Dim. L mm / in | Order Code |
|--|----------------|------------|
| Female Thread G 1/2" - PM0 | 80 / 3.15 | G1 |
| Female Thread 1/2" NPT - PM0 | 80 / 3.15 | N1 |
| Autoclave 9/16" MP - 13/16" - 16 UN Female Thread - only PH0 | 90 / 3.54 | P2 |

Manifold Pressure Ratings @ 120 °C / 248 °F

PM0 – 700 bar / 10150 psi

PH0 – 1220 bar / 17695 psi (20000 psi @ 50 °C / 122 °F)

| PM0 / PH0 Dimensions | mm | in |
|----------------------|-------------|-------|
| A | 164 | 6.46 |
| B | 58 | 2.28 |
| H1 (PM0, PH0) | 265 | 10.43 |
| H2 | 246 | 9.69 |
| H3 | 225 | 8.86 |
| W | see page 14 | |

Weights and Shipping Dimensions

- Weight for sensor with threads:
~6 kg/13.2 lb
- Shipping carton size: ~50 x 50 x 50 cm (20 x 20 x 20 in)
- Gross weight with RHE 28, packaging:
~12 kg/26.5 lb

Material of Manifold and Seals (Wetted Part)

The connection block/manifold is made of SS316L. Depending upon sensor temperature range, sensors are supplied with the following seal types as standard. For alternative seal options (e.g., FFKM seals for N1) please see Options Codes on page 18. Other seals on request.

| Temperature Range | PM0 | PH0 |
|-------------------|-------|------|
| N1 | FKM | FKM |
| NA | FVMQ | FVMQ |
| E2 | FFKM* | n/a |

*FFKM seals minimum temperature is -20 °C/-4 °F; $p_{max} = 700$ bar

Manifold design with threaded process connections

Serial tube / single measurement path
 Order Codes: SM0

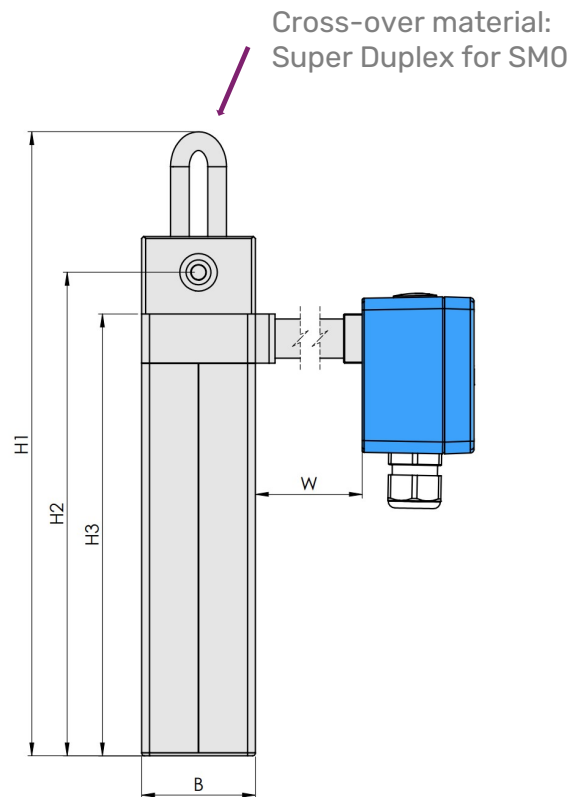
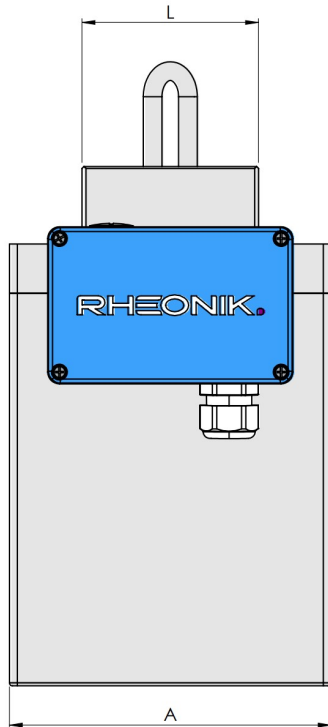

| SM0 Process Connection | Dim. L mm / in | Order Code |
|---------------------------|----------------|------------|
| Female Thread G ½"- SM0 | 90 / 3.54 | G1 |
| Female Thread ½" NPT- SM0 | 90 / 3.54 | N1 |

Manifold Pressure Ratings @ 120 °C / 248 °F
 SM0 – 700 bar / 10150 psi

| SM0 Dimensions | mm | in |
|----------------|-------------|-------|
| A | 164 | 6.46 |
| B | 58 | 2.28 |
| H1 | 318 | 12.52 |
| H2 | 246 | 9.69 |
| H3 | 225 | 8.86 |
| W | see page 14 | |

Weights and Shipping Dimensions

- Weight for sensor with threads:
~6 kg/13.2 lb
- Shipping carton size: ~50 x 50 x 50 cm
(20 x 20 x 20 in)
- Gross weight with RHE 28, packaging:
~12 kg/26.5 lb

Material of Manifold and Seals (Wetted Part)

The connection block/manifold is made of SS316L. Depending upon sensor temperature range, sensors are supplied with the following seal types as standard. For alternative seal options (e.g., FFKM seals for N1) please see Options Codes on page 18. Other seals on request.

| Temperature Range | SM0 | SH0 |
|-------------------|-------|------|
| N1 | FKM | FKM |
| NA | FVMQ | FVMQ |
| E2 | FFKM* | n/a |

*FFKM seals minimum temperature is -20 °C/-4 °F; p_{max} = 700 bar

Manifold design with flanged process connections

Parallel tube / dual measurement path

Order Code: PMO

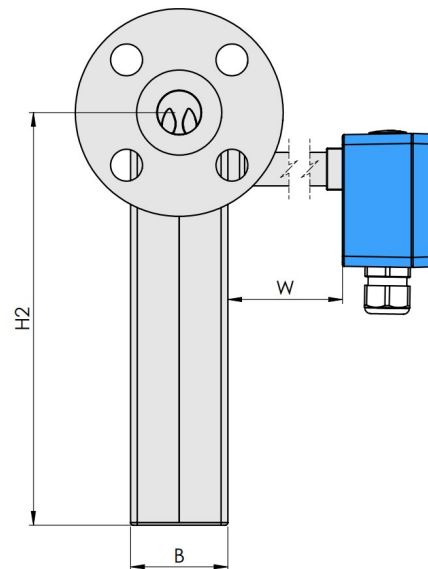
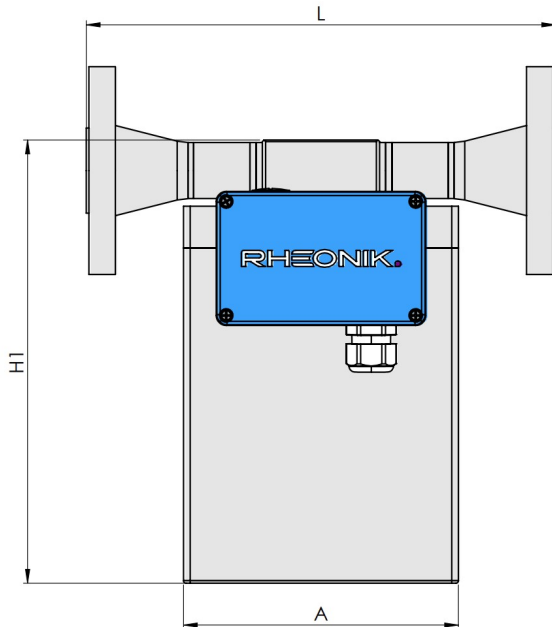

| PMO Process Connection | Dim. L mm / in | Order Code |
|--|----------------|------------|
| Standard | | |
| Flange ANSI 1" 150# RF/SF | 280 / 11.02 | A1 |
| Flange ANSI 1" 300# RF/SF | 280 / 11.02 | A2 |
| Flange ANSI 1" 600# RF/SF | 300 / 11.81 | A3 |
| Flange ANSI 1" 1500# RF/SF | 340 / 13.39 | A4 |
| Flange ANSI 1" 1500# RTJ | 340 / 13.39 | R1 |
| Flange DIN DN25/PN40 Form B1 | 280 / 11.02 | D1 |
| Flange DIN DN25/PN100 Form B2 | 300 / 11.81 | D2 |
| Flange JIS B 2220 RF 10k 25A (1") | 280 / 11.02 | J1 |
| Flange JIS B 2220 RF 20k 25A (1") | 280 / 11.02 | J2 |
| Non-Standard (longer lead times, extra price) | | |
| Flange ANSI ½" 150# RF/SF | 260 / 10.24 | AA |
| Flange ANSI ½" 300# RF/SF | 260 / 10.24 | AB |
| Flange ANSI ½" 600# RF/SF | 280 / 11.02 | AC |
| Flange ANSI ½" 1500# RTJ | 320 / 12.60 | RA |
| Flange DIN DN15/PN40 Form B1 | 280 / 11.02 | DA |
| Flange DIN DN15/PN100 Form B2 | 280 / 11.02 | DB |
| Flange JIS B 2220 RF 10k 15A (1/2") | 260 / 10.24 | JA |
| Flange JIS B 2220 RF 20k 15A (1/2") | 260 / 10.24 | JB |

Weights and Shipping Dimensions

- Weight for sensor with 1" 150# flanges: ~8 kg/17.6 lb
- Shipping carton size: ~50 x 50 x 50 cm (20 x 20 x 20 in)
- Gross weight with RHE 28, packaging: ~14 kg/30.9 lb

| PMO Dimensions | mm | in |
|----------------|-------------|-------|
| A | 164 | 6.46 |
| B | 58 | 2.28 |
| H1 | 265 | 10.43 |
| H2 | 246 | 9.69 |
| W | see page 14 | |

Material of Manifold and Seals (Wetted Part)

The connection block/manifold is made of SS316L. Depending upon sensor temperature range, sensors are supplied with the following seal types as standard. For alternative seal options (e.g., FFKM seals for N1) please see Options Codes on page 18. Other seals on request.

| Temperature Range | PMO |
|-------------------|-------|
| N1 | FKM |
| NA | FVMQ |
| E2 | FFKM* |

*FFKM seals minimum temperature is -20 °C/-4 °F; p_{max} = 700 bar

Manifold design with flanged process connections

Serial tube / single measurement path
Order Code: SMO

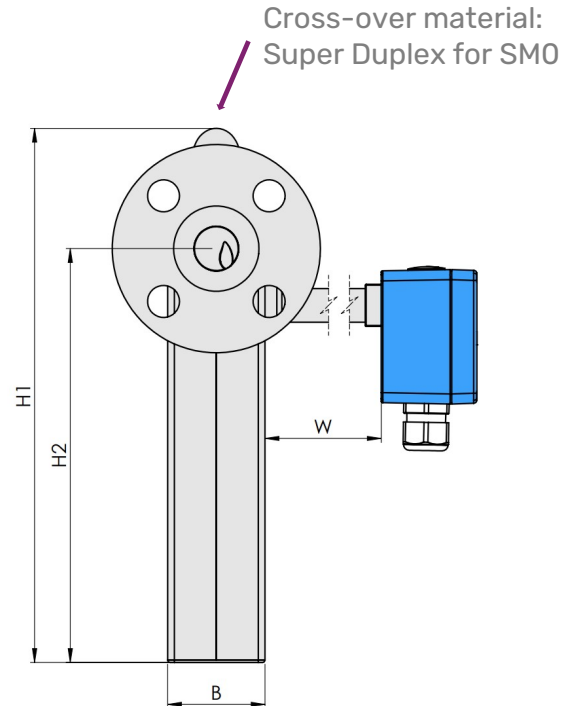
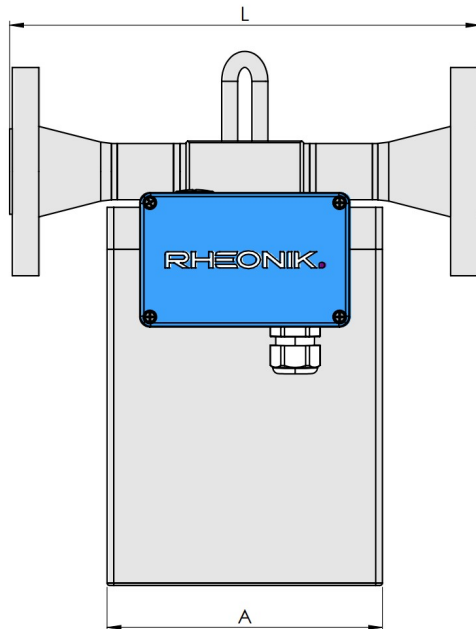

| SMO Process Connection | Dim. L mm / in | Order Code |
|--|----------------|------------|
| Standard | | |
| Flange ANSI 1" 150# RF/SF | 280 / 11.02 | A1 |
| Flange ANSI 1" 300# RF/SF | 280 / 11.02 | A2 |
| Flange ANSI 1" 600# RF/SF | 300 / 11.81 | A3 |
| Flange ANSI 1" 1500# RF/SF | 340 / 13.39 | A4 |
| Flange ANSI 1" 1500# RTJ | 340 / 13.39 | R1 |
| Flange DIN DN25/PN40 Form B1 | 280 / 11.02 | D1 |
| Flange DIN DN25/PN100 Form B2 | 300 / 11.81 | D2 |
| Flange JIS B 2220 RF 10k 25A (1") | 280 / 11.02 | J1 |
| Flange JIS B 2220 RF 20k 25A (1") | 280 / 11.02 | J2 |
| Non-Standard (longer lead times, extra price) | | |
| Flange ANSI ½" 150# RF/SF | 260 / 10.24 | AA |
| Flange ANSI ½" 300# RF/SF | 260 / 10.24 | AB |
| Flange ANSI ½" 600# RF/SF | 280 / 11.02 | AC |
| Flange ANSI ½" 1500# RTJ | 320 / 12.60 | RA |
| Flange DIN DN15/PN40 Form B1 | 280 / 11.02 | DA |
| Flange DIN DN15/PN100 Form B2 | 280 / 11.02 | DB |
| Flange JIS B 2220 RF 10k 15A (1/2") | 260 / 10.24 | JA |
| Flange JIS B 2220 RF 20k 15A (1/2") | 260 / 10.24 | JB |

Weights and Shipping Dimensions

- Weight for sensor with 1" 150# flanges: ~8 kg/17.6 lb
- Shipping carton size: ~50 x 50 x 50 cm (20 x 20 x 20 in)
- Gross weight with RHE 28, packaging: ~14 kg/30.9 lb

| SMO Dimensions | mm | in |
|----------------|-------------|-------|
| A | 164 | 6.46 |
| B | 58 | 2.28 |
| H1 | 318 | 12.52 |
| H2 | 246 | 9.69 |
| W | see page 14 | |

Material of Manifold and Seals (Wetted Part)

The connection block/manifold is made of SS316L. Depending upon sensor temperature range, sensors are supplied with the following seal types as standard. For alternative seal options (e.g., FFKM seals for N1) please see Options Codes on page 18. Other seals on request.

| Temperature Range | SMO |
|-------------------|-------|
| N1 | FKM |
| NA | FVMQ |
| E2 | FFKM* |

*FFKM seals minimum temperature is -20 °C/-4 °F; p_{max} = 700 bar

Sealless design with flanged/hub process connections

Parallel tube / dual measurement path

Order Code: PF0

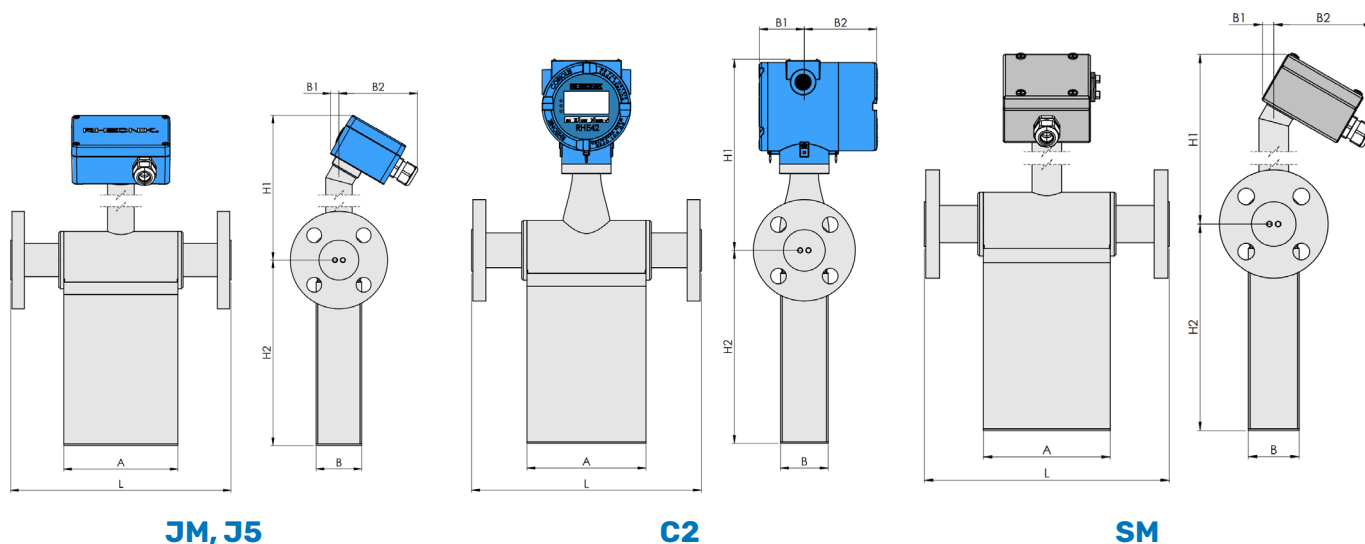

| PF0 Process Connection | Dim. L mm / in | Order Code |
|-------------------------------------|----------------|------------|
| Flange ANSI 1" 150# RF/SF | 280 / 11.02 | A1 |
| Flange ANSI 1" 300# RF/SF | 280 / 11.02 | A2 |
| Flange ANSI 1" 600# RF/SF | 280 / 11.02 | A3 |
| Flange ANSI 1" 1500# RF/SF | 320 / 12.60 | A4 |
| Flange ANSI 1" 1500# RTJ | 320 / 12.60 | R1 |
| Flange ANSI 1" 2500# RTJ | 320 / 12.60 | R2 |
| Flange DIN DN25/PN40 Form B1 | 280 / 11.02 | D1 |
| Flange DIN DN25/PN100 Form B2 | 300 / 11.81 | D2 |
| Flange JIS B 2220 RF 10k 25A (1") | 280 / 11.02 | J1 |
| Flange JIS B 2220 RF 20k 25A (1") | 280 / 11.02 | J2 |
| Grayloc® Hub 1" GR5 - only Type _F0 | 300 / 11.81 | H1 |

For other hub connections (e.g. Destec, Galperti, Techlok) please consult factory

| PF0 Dimensions | mm | in |
|----------------|-----|------|
| A | 145 | 5.71 |
| B | 58 | 2.28 |
| H2 | 236 | 9.29 |
| B1 (JM, J5) | 11 | 0.43 |
| B2 (JM, J5) | 100 | 3.94 |
| H1 (JM, J5) | 197 | 7.76 |
| B1 (C2) | 55 | 2.17 |
| B2 (C2) | 88 | 3.46 |
| H1 (C2) | 234 | 9.21 |
| B1 (SM) | 13 | 0.51 |
| B2 (SM) | 113 | 4.45 |
| H1 (SM) | 192 | 7.56 |

Weights and Shipping Dimensions

- Weight for sensor with 1" 150# flanges: ~7 kg/15.4 lb
- Shipping carton size: ~50 x 50 x 50 cm (20 x 20 x 20 in)
- Gross weight with RHE 28, packaging: ~13 kg/28.7 lb

Sealless design with threaded process connections

Parallel tube / dual measurement path

Order Code: PFT

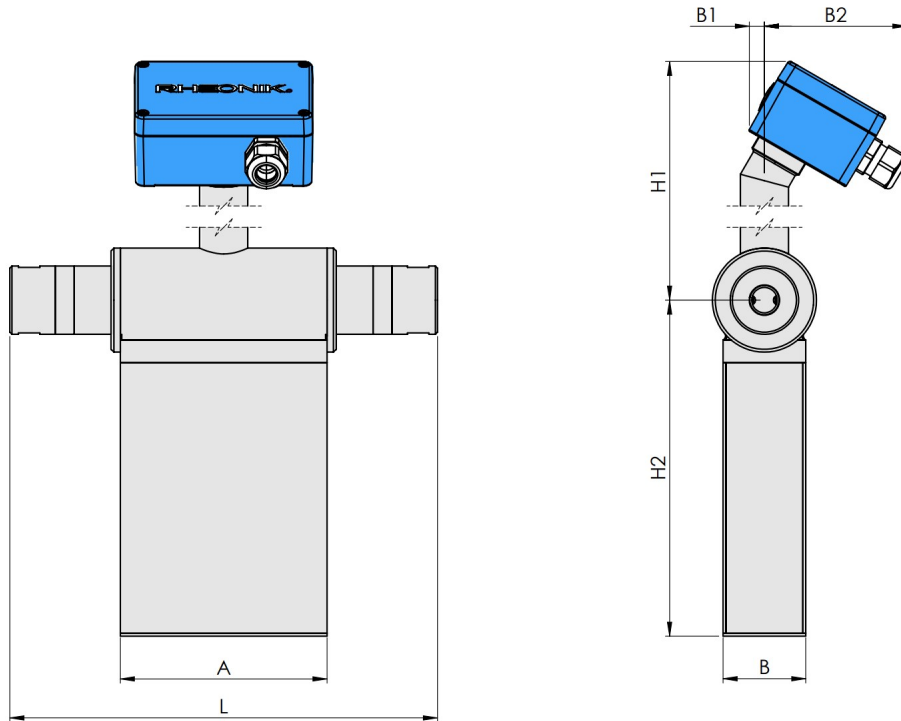

| PFT Process Connection | Dim. L mm / in | Order Code |
|---|----------------|------------|
| Female Thread G 1/2" | 300 / 11.81 | G1 |
| Female Thread 1/2" NPT | 300 / 11.81 | N1 |
| Autoclave 9/16" MP - 13/16" - 16 UN Female Thread | 300 / 11.81 | P2 |

| PFT Dimensions | mm | in |
|----------------|-----|------|
| A | 145 | 5.71 |
| B | 58 | 2.28 |
| H2 | 236 | 9.29 |
| B1 (JM, J5) | 11 | 0.43 |
| B2 (JM, J5) | 100 | 3.94 |
| H1 (JM, J5) | 197 | 7.76 |
| B1 (C2) | 55 | 2.17 |
| B2 (C2) | 88 | 3.46 |
| H1 (C2) | 234 | 9.21 |
| B1 (SM) | 13 | 0.51 |
| B2 (SM) | 113 | 4.45 |
| H1 (SM) | 192 | 7.56 |

Weights and Shipping Dimensions

- Weight for sensor with threads:
~6.5 kg/14.3 lb
- Shipping carton size: ~50 x 50 x 50 cm (20 x 20 x 20 in)
- Gross weight with RHE 28, packaging:
~12.5 kg/27.6 lb

Material and pressure rating of process connection:

Generally, the material of the connection is identical to the measurement tube material selected. Exception may occur, e.g., Swagelok is always SS316.

The pressure rating for G thread is 540bar@120°C, 700bar@120°C for NPT.

Sealless design with flanged/hub and threaded process connections for E3/H4 temperature range

Parallel tube / dual measurement path
Order Code: PFO/PFT

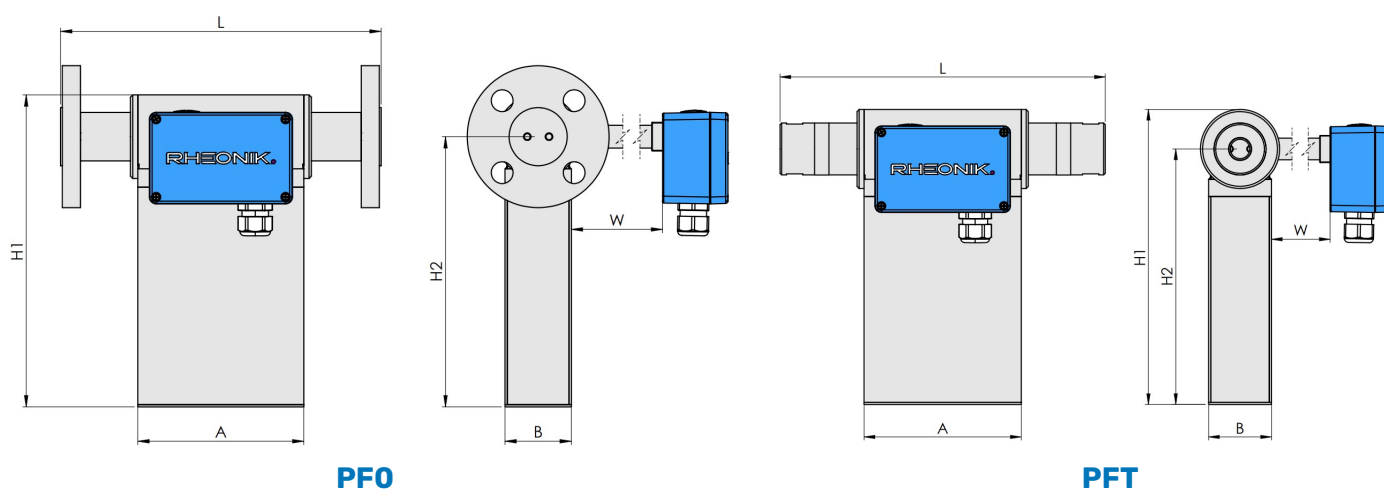

| PFO Process Connection | Dim. L mm / in | Order Code |
|-------------------------------------|----------------|------------|
| Flange ANSI 1" 150# RF/SF | 280 / 11.02 | A1 |
| Flange ANSI 1" 300# RF/SF | 280 / 11.02 | A2 |
| Flange ANSI 1" 600# RF/SF | 280 / 11.02 | A3 |
| Flange ANSI 1" 1500# RF/SF | 320 / 12.60 | A4 |
| Flange ANSI 1" 1500# RTJ | 320 / 12.60 | R1 |
| Flange ANSI 1" 2500# RTJ | 320 / 12.60 | R2 |
| Flange DIN DN25/PN40 Form B1 | 280 / 11.02 | D1 |
| Flange DIN DN25/PN100 Form B2 | 300 / 11.81 | D2 |
| Flange JIS B 2220 RF 10k 25A (1") | 280 / 11.02 | J1 |
| Flange JIS B 2220 RF 20k 25A (1") | 280 / 11.02 | J2 |
| Grayloc® Hub 1" GR5 - only Type _F0 | 300 / 11.81 | H1 |

For other hub connections (e.g. Destec, Galperti, Techlok) please consult factory

| PFT Process Connection | Dim. L mm / in | Order Code |
|---|----------------|------------|
| Female Thread G 1/2" | 300 / 11.81 | G1 |
| Female Thread 1/2" NPT | 300 / 11.81 | N1 |
| Autoclave 9/16" MP - 13/16" - 16 UN Female Thread | 300 / 11.81 | P2 |

| PFO/PFT E3/H4 Dimensions | mm | in |
|--------------------------|-------------|-------|
| A | 145 | 5.71 |
| B | 58 | 2.28 |
| H1 | 273 | 10.75 |
| H2 | 236 | 9.29 |
| W | see page 14 | |

Weights and Shipping Dimensions

- Weight for sensor with 1" 150# flanges: ~7 kg/15.4 lb
- Shipping carton size: ~50 x 50 x 50 cm (20 x 20 x 20 in)
- Gross weight with RHE 28, packaging: ~13 kg/28.7 lb

Electrical Connection Options To Transmitters

Any Rheonik Mass Flow Transmitter model can be combined with any Rheonik Mass Flow Sensor to provide an overall mass flow measurement system to suit any requirement. Rheonik Coriolis transmitters are available in both integral and remote mounting styles. A range of connection options is available to suit all application requirements.

Order Code: JM
 (J5 with RHE45 Integral Transmitter)
 Standard Coated Aluminum Terminal Box

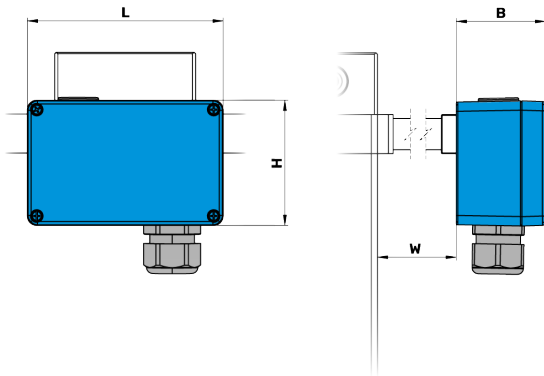

Order Code: PM
 Compact Coated Aluminum Terminal Box

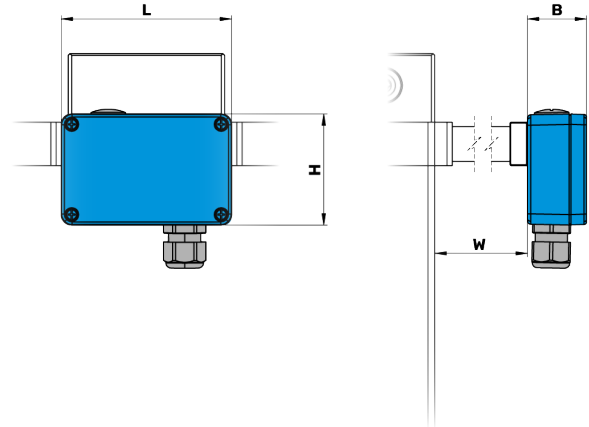

Order Code: SM
 Terminal Box and Entire Enclosure in SS 316L/Ti

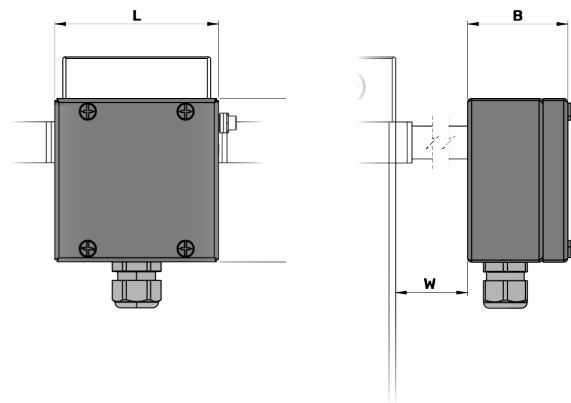

Order Code: TM
 Integral PTFE Cable (No Terminal Box). Std. Length 2 m. Can be extended up to max 10 m

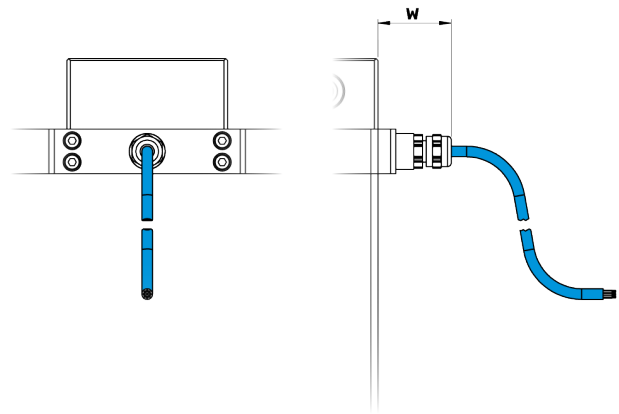

| Connection Option | Dimension | mm | in |
|--|-----------|----------------|--------------------|
| JM, J5 Terminal Box | L x H x B | 125 x 80 x 57 | 4.92 x 3.15 x 2.24 |
| PM Compact Terminal Box | L x H x B | 98 x 64 x 34 | 3.86 x 2.52 x 1.34 |
| SM SS316L Terminal Box | L x H x B | 100 x 100 x 61 | 3.94 x 3.94 x 2.40 |
| TM Integral PTFE Cable | W | 41 | 1.61 |
| JM, J5, PM, SM with Temperature Range N1, NA | W | 2 | 0.08 |
| JM, J5, PM, SM with Temperature Range E2, E3 | W | 100 | 3.94 |

JM, SM Terminal boxes are supplied with an M20 x 1.5 cable entry, optional entries available – see Separately Ordered Options, page 18
 PM Compact Terminal boxes are supplied with an M16 x 1.5 cable entry
 For details of the integral transmitter used with option J5, please see the RHE45 datasheet

Installation/Mounting Schemes

Recommended for sensitive, low flow installations (order codes see page 18 "Accessories")

Pipe Support Brackets

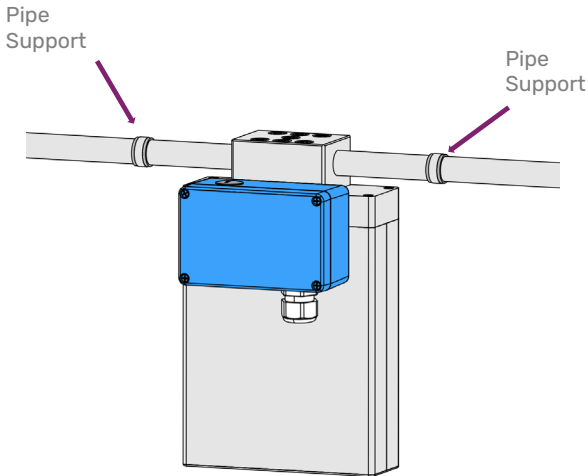

Sensor Mounting Holes (backside of the sensor)

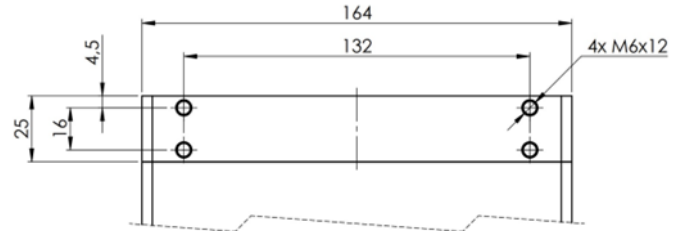

Thread dimensions ground plate PF0/PFT

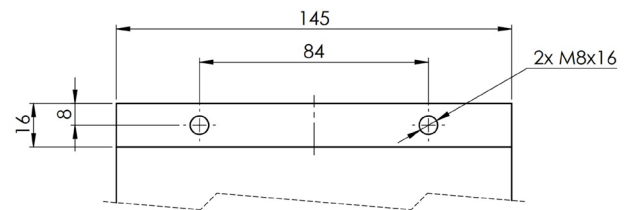

Wall Mounting Bracket Accessory

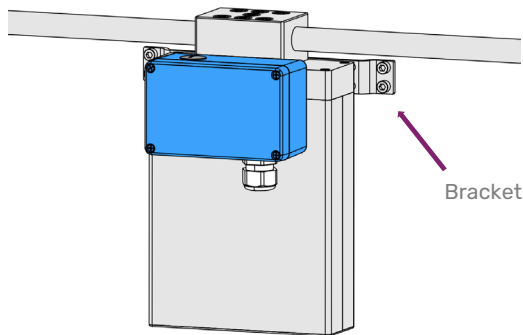

Floor Mounting "Foot" Bracket Accessory

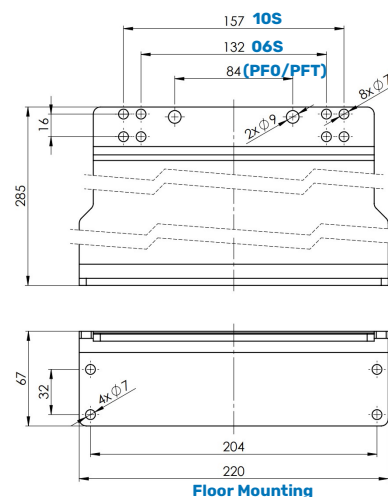
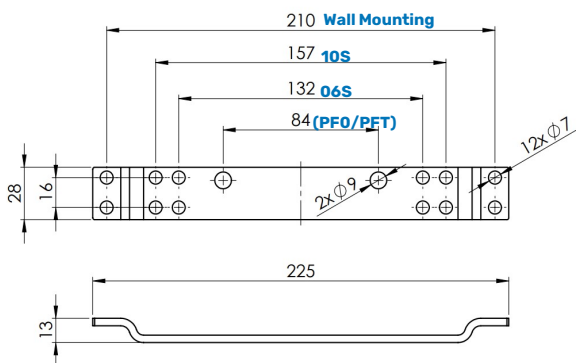
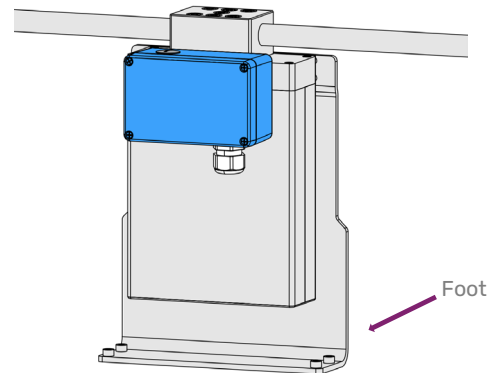

Electrical connection to transmitter compatibility

Electrical connection option selections are compatible with the transmitter range according to the following table. Note that economical blind front versions of some transmitters are available where displays and keypads are not required. The wide range of Rheonik sensors and transmitters provide tremendous options for system designers and end users alike.

| Sensor Connection Options |  | | | | | | |
|---|--|----|----|----|----|----|----|
| | Order Code | JM | SM | TM | J5 | C2 | PM |
|  | RHE 21 | ✓ | ✓ | ✓ | — | — | ✓ |
|  | RHE 26 | ✓ | ✓ | ✓ | — | — | ✓ |
|  | RHE 27 | ✓ | ✓ | ✓ | — | — | ✓ |
|  | RHE 28 | ✓ | ✓ | ✓ | — | — | ✓ |
|  | RHE 42 | ✓ | ✓ | ✓ | — | ✓ | ✓ |
|  | RHE 45 | — | — | — | ✓ | — | — |
|  | RHE 46 | ✓ | ✓ | ✓ | — | — | ✓ |

RHM 06 Part Number Code

Temperature Range

- N1 NT from -20 to +120°C (-4 to +248°F)
- NA ET from -50 to +120°C (-58 to +248°F)
- E2 ET2 from -50 to +210°C (-58 to +410°F)
- E3 ET1 from -196 to +50°C (-321 to +122°F) - only sealless
- H4 HT from -20 to +350°C (-4 to +662°F) - only sealless

Pressure Code for p_{max} of Measuring Loops

See pressure ratings page for ratings and codes

Construction Type - p_{max} indications refer to 120°C / 248°F

- PM0 Parallel block/manifold in SS316L with seals, p_{max} = 700 bar
- SM0 Serial block/manifold in SS316L with seals, p_{max} = 700 bar
- PH0 Parallel block/manifold in SS316L with seals, p_{max} = 1220 bar (20000 psi @ 50°C / 122°F) - only Autoclave
- PFO Parallel tube, sealless - only with flange and hub connections
- PFT Parallel tube, sealless - only with thread connections

Material of Measuring Loops

- 04 SS316L / EN 1.4404 / UNS S31603 (standard for P1)
- 35 SS316L / EN 1.4435 / UNS S31603 (standard for P2)
- 10 SuperDuplex / EN 1.4410 / UNS S32750
- M3 Alloy C22 / EN 2.4602 / UNS N06022 - only sealless

Process Connection

See mechanical construction pages for available connections and codes

Electrical Connection to Transmitter

- JM Terminal Box coated Aluminum - M20 x 1.5 cable entry, see Accessories for others - not with Haz. Area A0
- J5 Alu Box ready for integrated RHE45 - temp. restrictions apply - only Haz. Area NN
- PM Extra compact Terminal Box coated Aluminum - M16 x 1.5 cable entry - not with Haz. Area A0, No Option T1
- SM Terminal Box and entire Enclosure/Housing in SS 316L/Ti - M20 x 1.5 cable entry, see Accessories for others
- TM Integral PTFE cable to RHE, 2m - not with H4 Temperature, Haz. Area A0. C0 only with Temp. N1, NA
- C2 Prepared for compact transmitter mount RHE42 - temperature restrictions apply

Options Codes

See options listing for specific codes

Hazardous Area Certifications (details see page 19)

- NN Without Ex Approval
- A2 ATEX/IECEx Approvals Zone 2
- A1 ATEX/IECEx Approvals Zone 1 - requires suitably rated RHE
- A0 ATEX/IECEx Approvals Zone 0 - requires Elec. Conn. SM, suitably rated RHE
- C2 CSA Approval US-Canada Class I, Zone 2, Gas IIC
- C0 CSA Approval US-Canada Class I, Div. 1 / Zone 0, Gas IIC - requires suitable rated RHE

Pressure Design Compliance

- NN Rheonik standard design based on EN codes (no PED - not for sales into EU)
- SE PED compliance according to SEP - Sound Engineering Practice

Performance Certification

- NN No Performance Certification
- AB ABS Approval for marine applications - includes Approval for RHE Transmitter
- DV DNV approval for marine applications - requires RHE42/45, only for RHM with flange connection
- R9 OIML R139 approval for hydrogen dispensers - requires RHE2x
- MH MID MI002 approval for H2 metering - requires RHE2x

Mass Flow, Density Calibration Selection

See performance page for code options

Manufacturing Instruction Codes

See instructions listing for specific codes (next page)

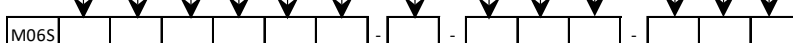

Options Codes

| Order Code | |
|------------|--|
| NN | No options selected |
| T1 | Terminal box with cable entry upwards/gas installation |
| T0 | Set-off terminal box for N1, NA temperature range (included in E2, E3) |
| FO | FVMQ seals for manifolds instead of standard seals - <i>recommended for frequent use < 0 °C</i> |
| FK | FFKM* seals for manifolds instead of standard seals - <i>high chemical resistance, p_{max} = 700 bar</i> |
| EP | EPDM** seals for manifolds instead of standard seals - <i>recommended for refrigerants</i> |

*FFKM seals minimum temperature is -20°C / -4°F

**EPDM seals only for N1, NA temperature range (-50 - +120°C), only for p1, p2 pressure range, only _M0 construction type

List multiple options in the sensor part number in the same order as the above list

Manufacturing Instructions

| Order Code | |
|------------|--|
| N | No additional manufacturing instructions |
| F | Removal of rest water from calibration with compressed air |
| 7 | Upgrade to dual rating IP66/67 - <i>only with electrical connection SM</i> |
| O | Special Cleaning, water and fat free |
| S | Sea-worthy packing |

List multiple options in the sensor part number in the same order as the above list

Options

| Order Code ORHM-... | |
|------------------------|---|
| E1 | Terminal box prepared for ½" NPT cable entry |
| E2 | Terminal box prepared for M25x1.5 cable entry (<i>only with electrical connection SM</i>) |
| E3 | Terminal box prepared for ¾" NPT cable entry (<i>only with electrical connection SM</i>) |
| E5 | Terminal box prepared for M20 x 1.5 cable entry in SS316L (<i>only with electrical connection SM</i>) |
| E6 | Terminal box prepared for ½" NPT cable entry in SS316L (<i>only with electrical connection SM</i>) |
| TP | Separate TAG Plate in Stainless Steel (<i>TAG information only</i>) |
| TC | Type Label in Stainless Steel (<i>TAG and all other label information</i>) |

Standard cable entry on JM, SM terminal box is M20 x 1.5. Cable entry on PM terminal box is always M16 x 1.5

Accessories

| Order Code ARHM06/10- | |
|--------------------------|---|
| M | Wall mounting bracket - <i>highly recommended for sensitive, low flow installations</i> |
| MF | Floor mounting bracket |

Hazardous Area Certifications

| Order Code | Zone / Division | Approval | Labeling |
|------------|-----------------|---------------|---|
| A2 | Zone 2 | ATEX IECEX | ⊕ Ex II 3G Ex ec IIC T6...T1 Gc Ex ec IIC T6...T1 Gc |
| A1 | Zone 1 | ATEX IECEX | ⊕ Ex II 2G Ex ib IIC T6...T1 Gb Ex ib IIC T6...T1 Gb |
| A0 | Zone 0 | ATEX IECEX | ⊕ Ex II 1G Ex ia IIC T6...T1 Ga Ex ia IIC T6...T1 Ga |
| C2 | Zone 2 | USA/Canada | Class I, Zone 2, AEx nA IIC T6...T1 Gc |
| C0 | Div 1, Zone 0 | USA/Canada | Class I, Div 1, Groups A, B, C and D T6...T1; Class I, Zone 0, AEx ia IIC T6...T1 Ga |



About Rheonik

Rheonik has but one single purpose: to design and manufacture the very best Coriolis meters available.

Our research and engineering resources are dedicated to finding new and better ways to provide cost effective accurate mass flow solutions that provide value to our customers. Our manufacturing group care for each and every meter we produce from raw materials all the way to shipping, and our service and support group are available to help you specify, integrate, start-up and maintain every Rheonik meter you have in service. Whether you own just one meter or have hundreds, you will never be just another customer to us. You are our valued business partner.

Need a specific configuration for your plant? Don't compromise with a "standard" product from elsewhere that will add extra cost to your installation. If we can't configure it from our extensive and versatile product range, our exclusive **AnyPipeFit Commitment** can have your flow sensor customized with any size/type of process connection and face to face dimension you need.

No matter what control system you use as the backbone in your enterprise, with our **AnyInterface Commitment**, you can be sure that connection and communication will not be a problem. Alongside a wide variety of discrete analog and digital signal connections, we can also provide just about any network/bus interface available (for example: HART, ProfibusDP, ProfiNet, EtherCAT, PowerLink, EtherNet/IP, CAN,) with our RHE 40 Series family of transmitters. Rheonik RHE 40 Series transmitters can connect to your system – no headache and no conversion needed.

Rheonik Messtechnik GmbH
Rudolf-Diesel-Straße 5
D-85235 Odelzhausen
Germany

Tel + 49 (0)8134 9341-0
Info@rheonik.com

